

# Interfacing OLED Display to the AT89LV52 MCU

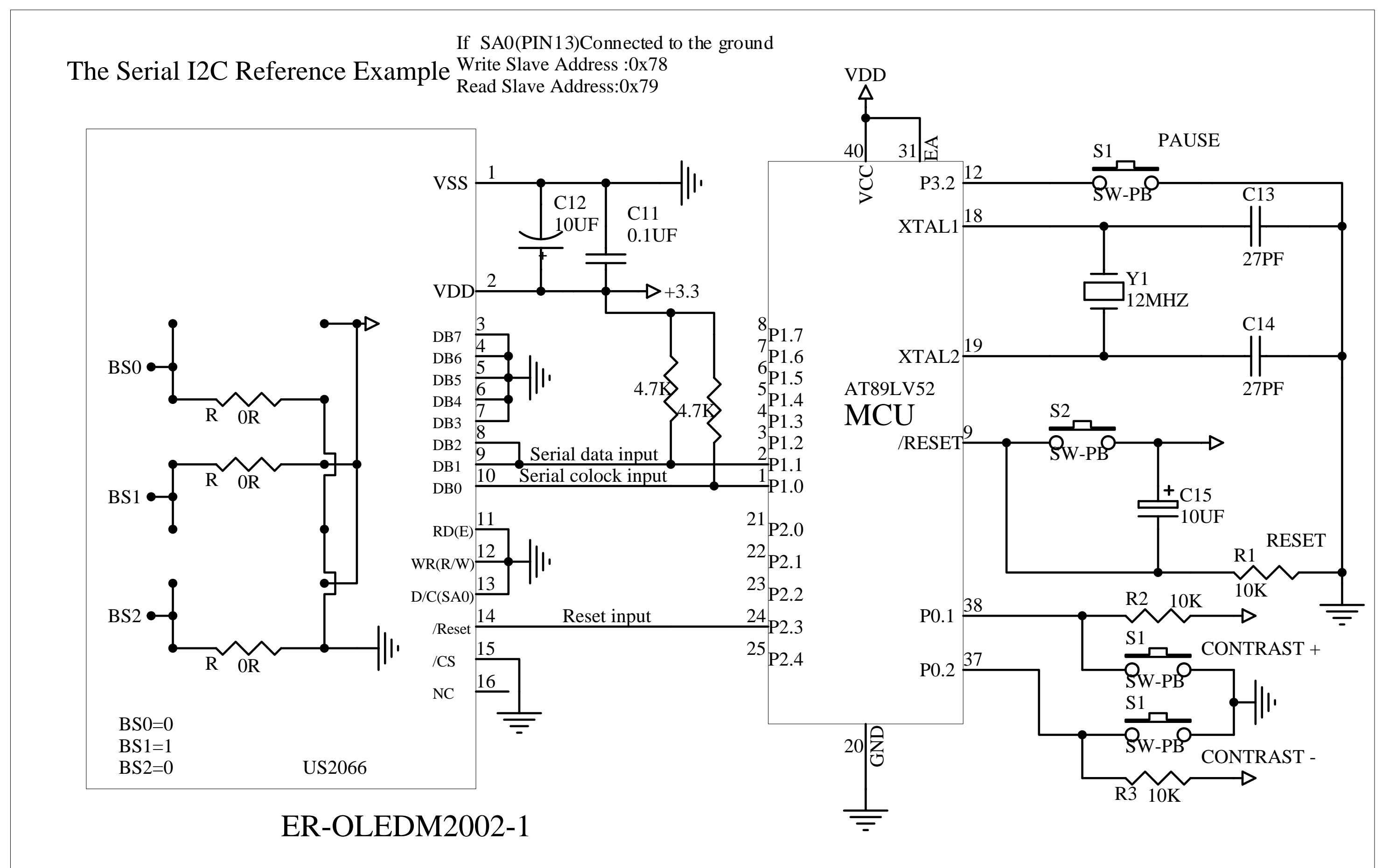
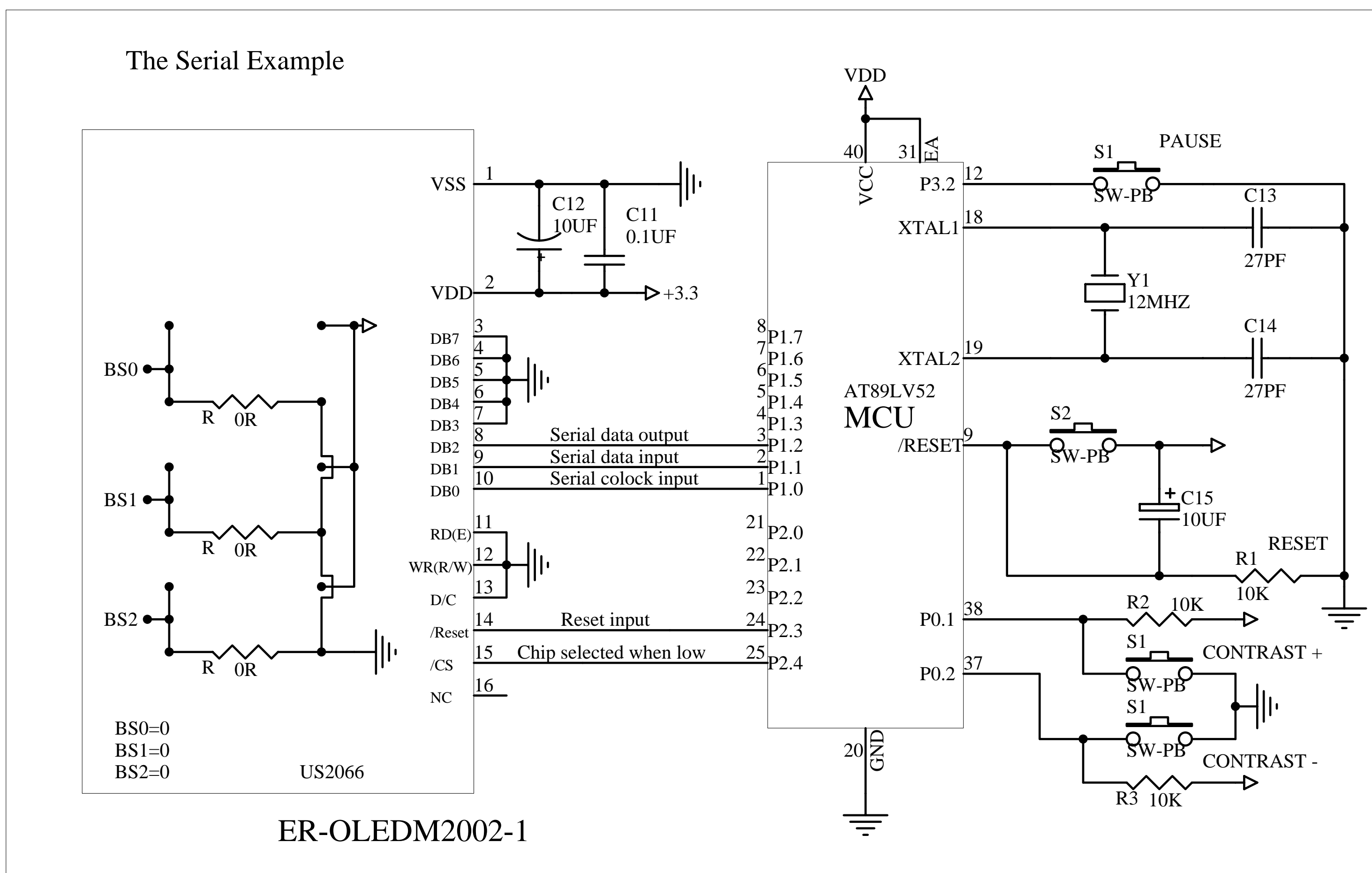
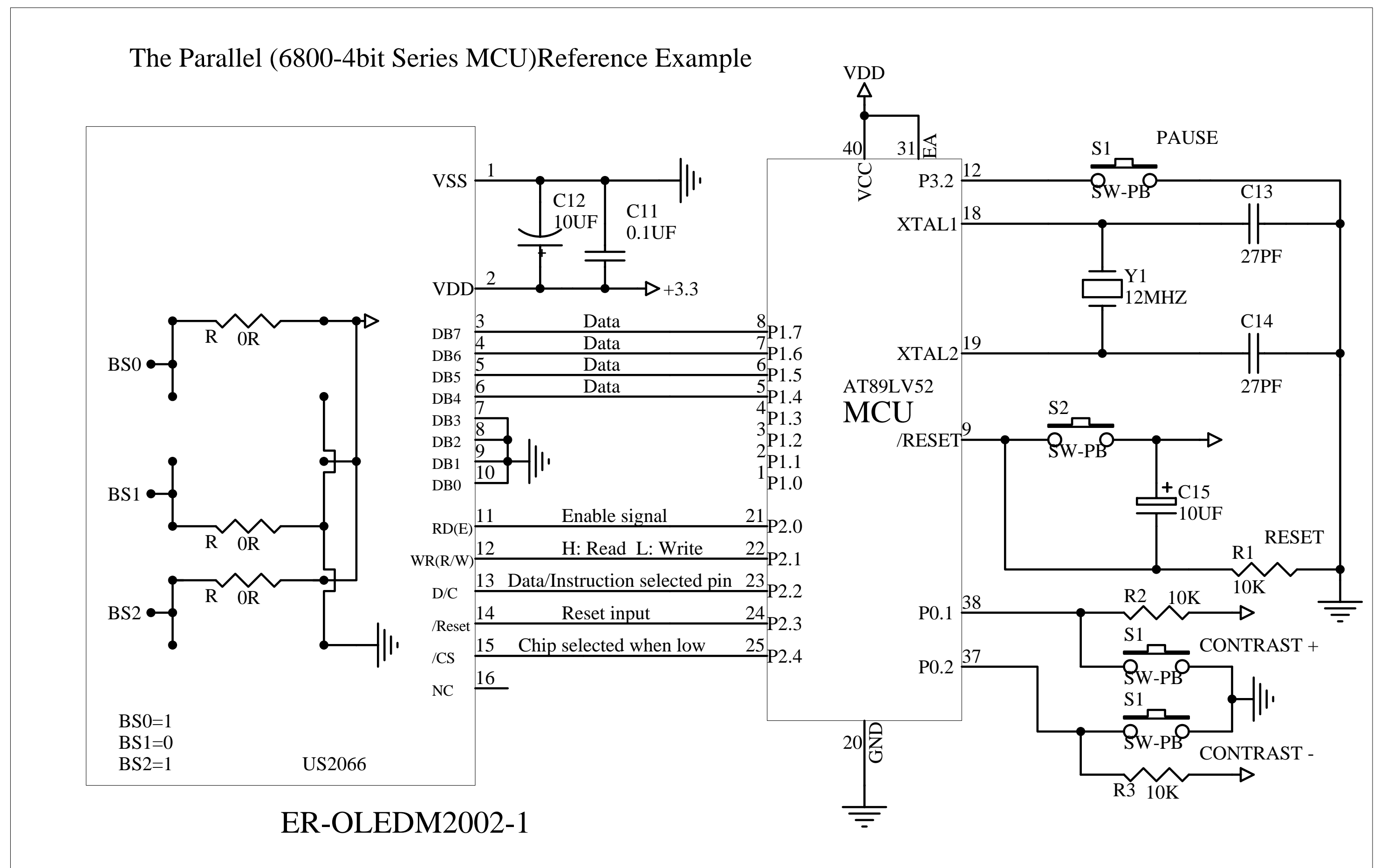
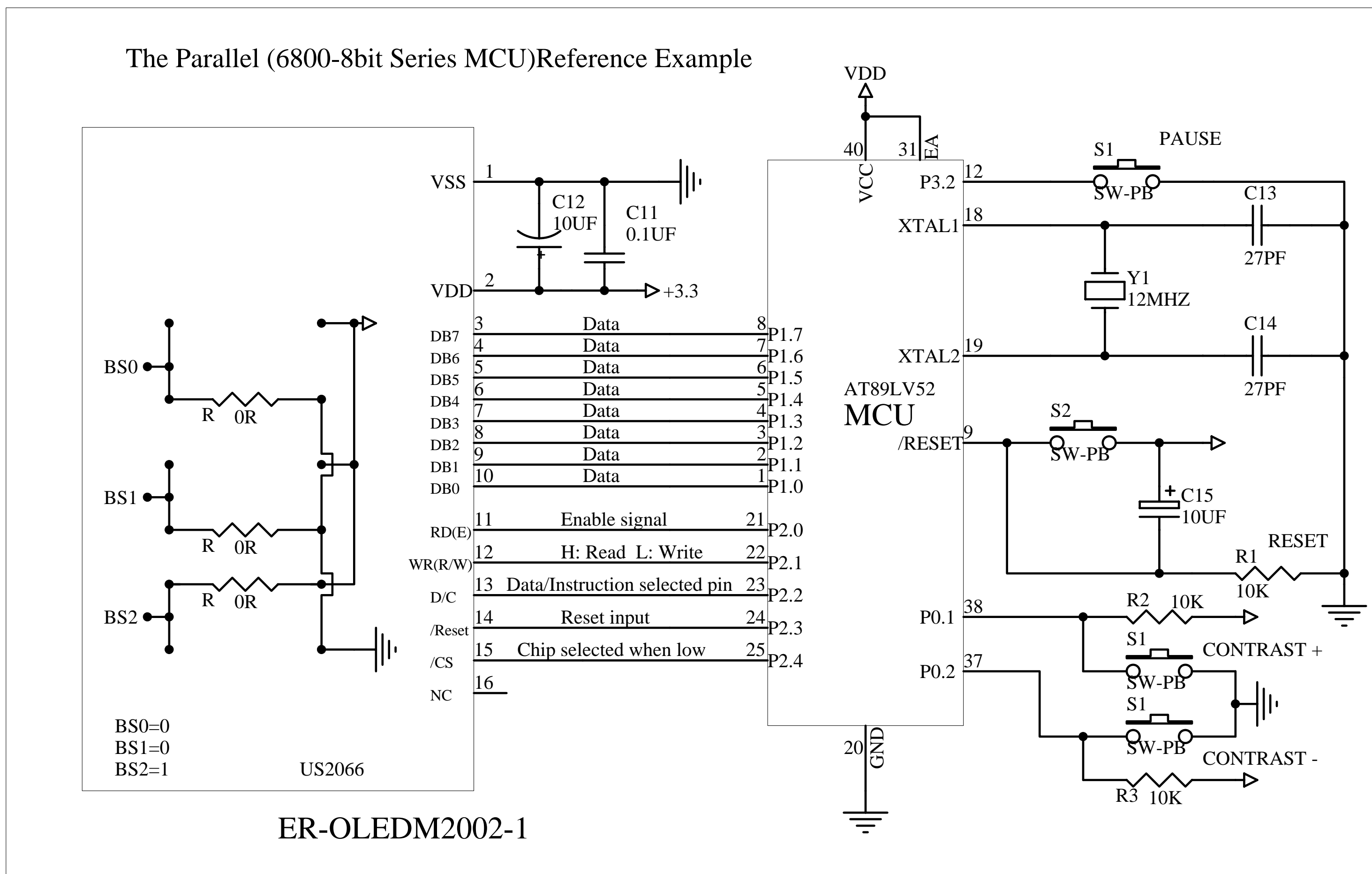
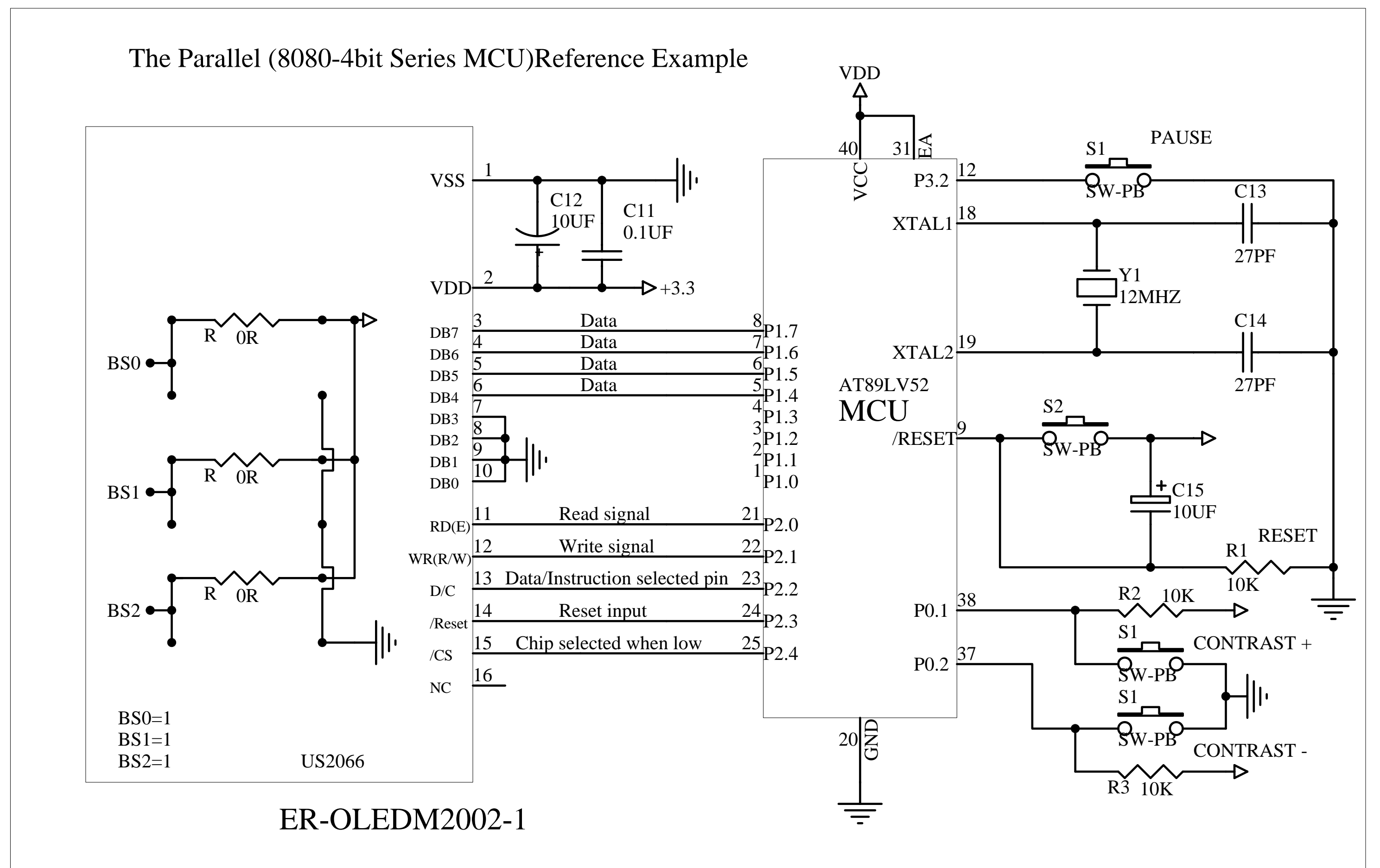
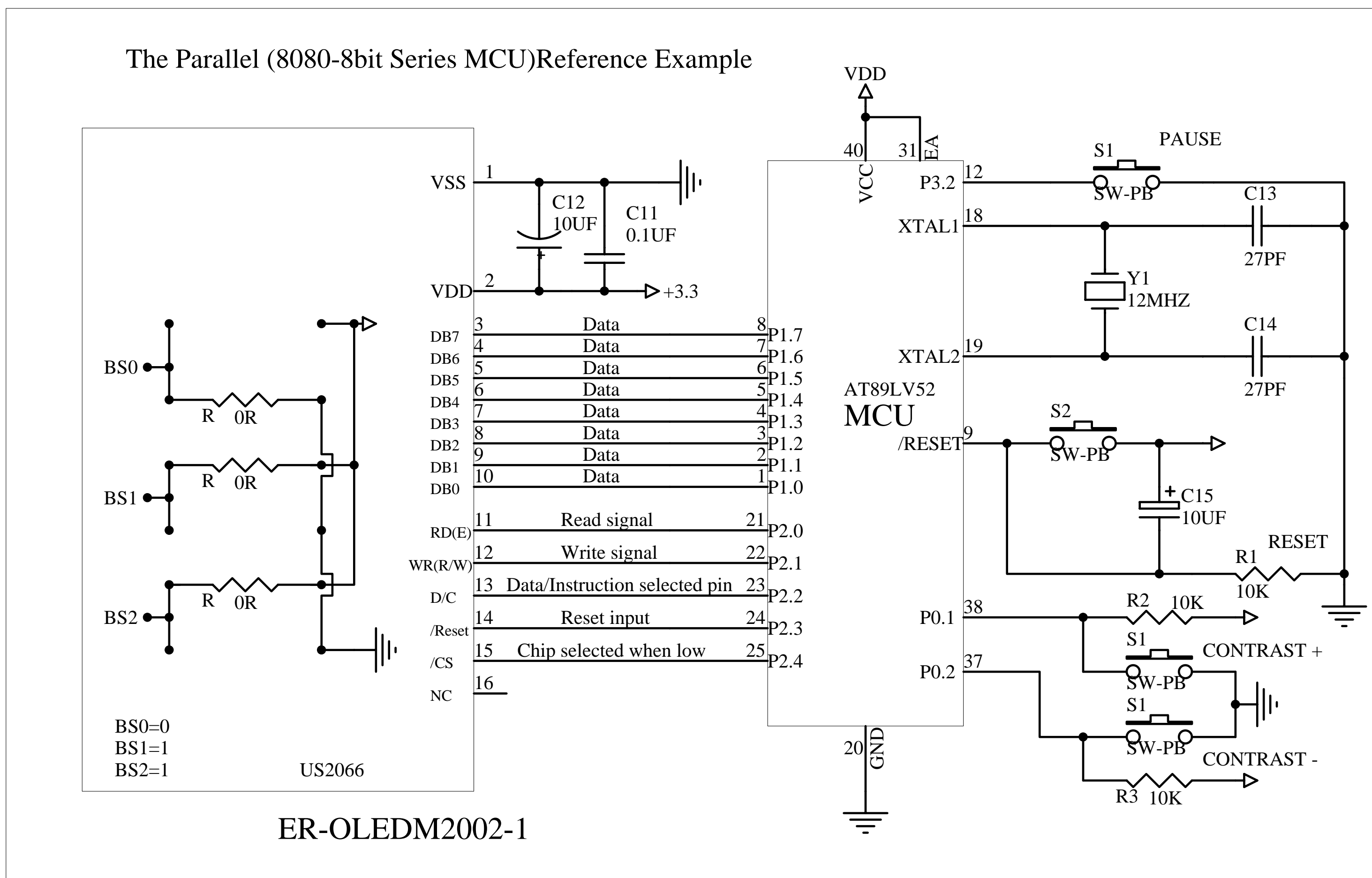

Title <b>EASTRISING TECHNOLOGY CO.,LTD.</b>			
Size	Number	Revision	
A	ER-OLEDM2002-1	A0	
Date:	03-Feb-2010	Sheet of	1
File		Drawn By	Javen