

TYPE A

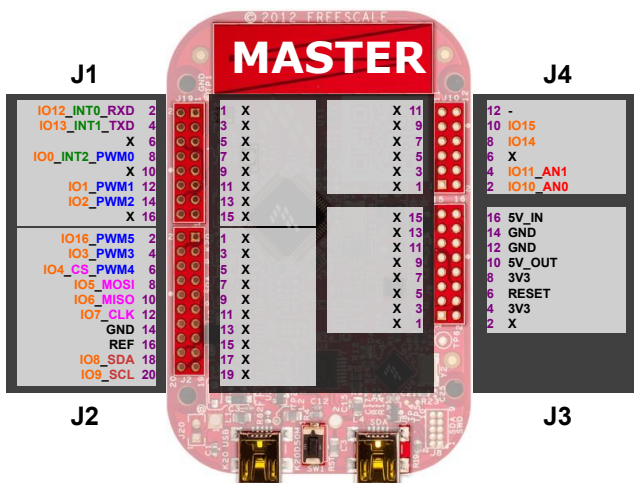

Works for all FRDM boards;
also based on Arduino UNO (no PWM on J2/2) and Arduino MEGA (no INT on J1/4, SPI on J2/6/8/10/12)
NOTE: The KE04Z has the MOSI and MISO pins swapped on J2/8/10
The KL27Z does not have an interrupt on J1/8

TYPE B

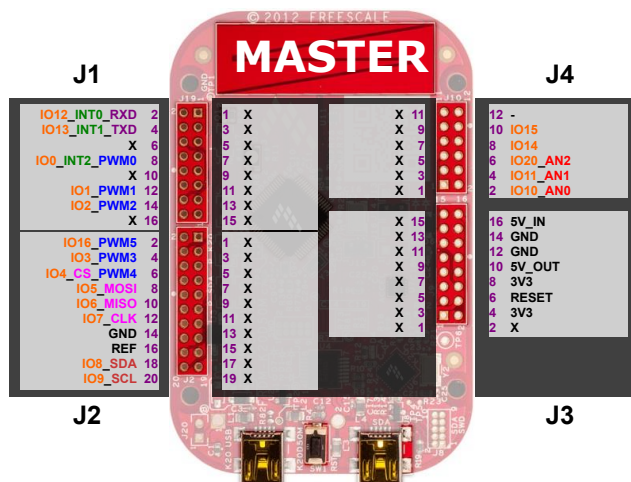

No KE04Z;
also based on Arduino UNO (no PWM on J2/2) and Arduino MEGA (no INT on J1/4, SPI on J2/6/8/10/12)
NOTE: The KE04Z has the MOSI and MISO pins swapped on J2/8/10
The KL27Z does not have an interrupt on J1/8

TYPE C

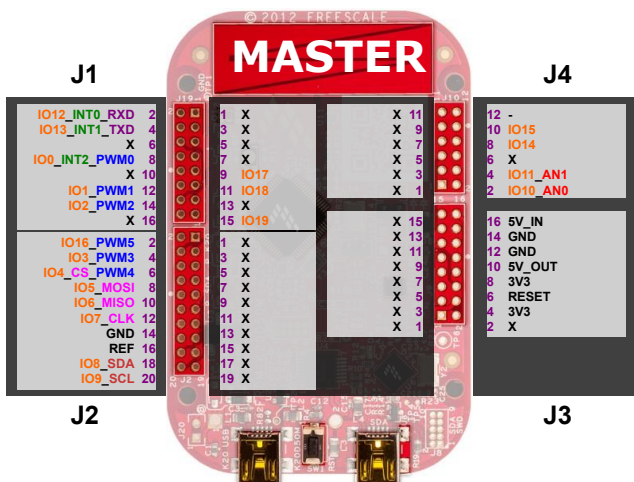

KL02Z, KL03Z, KL05Z;
also based on Arduino UNO (no PWM on J2/2) and Arduino MEGA (no INT on J1/4, SPI on J2/6/8/10/12)
NOTE: Arduino do not connect to odd pins
The KE04Z has the MOSI and MISO pins swapped on J2/8/10
The KL27Z does not have an interrupt on J1/8

TYPE D

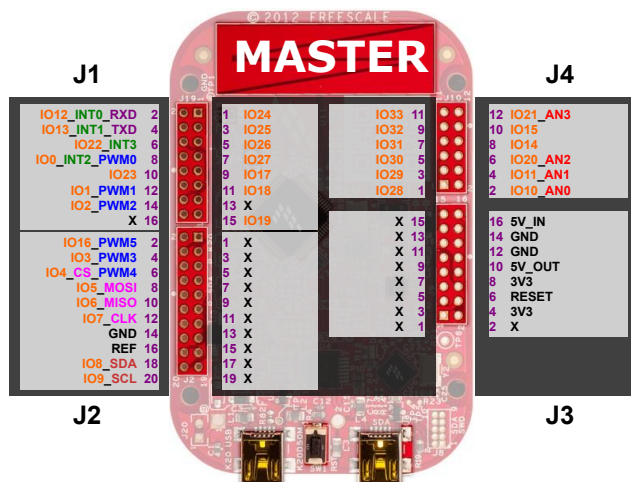

No KE04Z, KL02Z, KL03Z, KL05Z;
also based on Arduino UNO (no PWM on J2/2) and Arduino MEGA (no INT on J1/4, SPI on J2/6/8/10/12)
NOTE: Arduino do not connect to odd pins
The KE04Z has the MOSI and MISO pins swapped on J2/8/10
The KL27Z does not have an interrupt on J1/8