

# Expansion Connectors

## mbed Interface

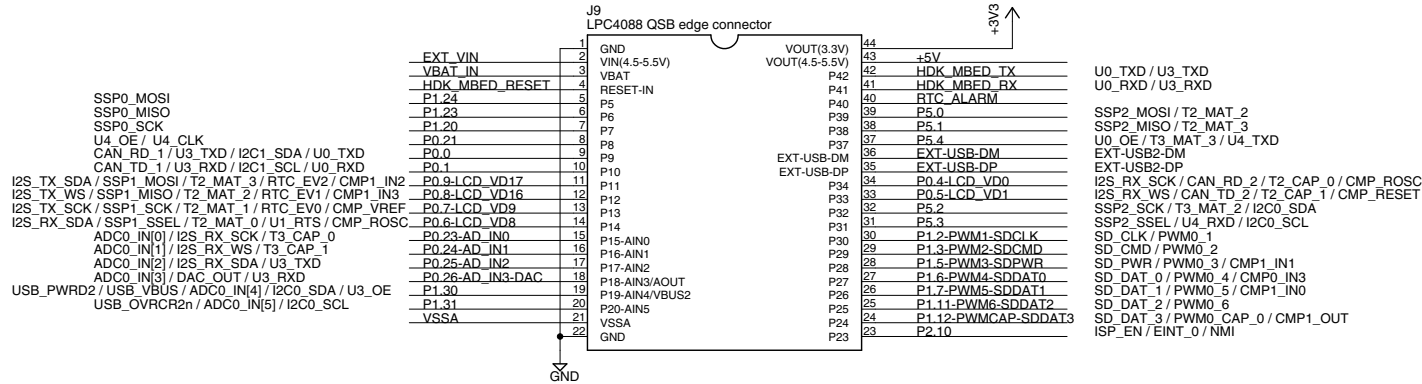

## Display Interface

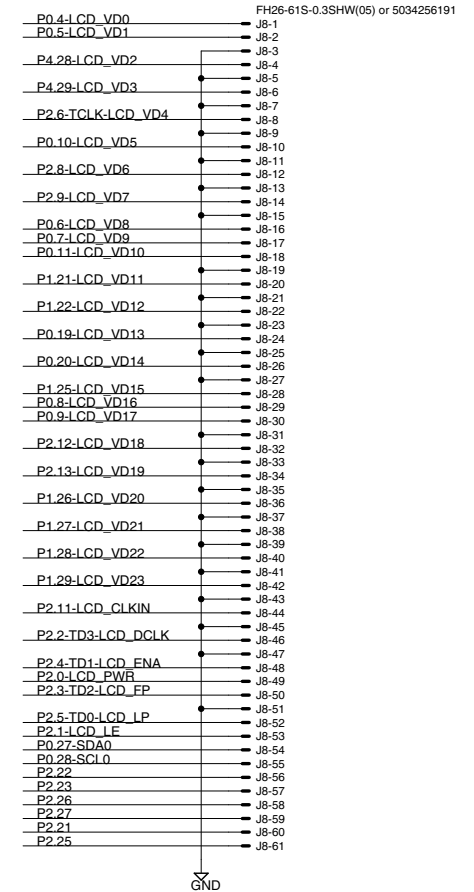

mbed LPC1768	LPC4088 QuickStart Board
GND	GND
VIN (4-11V)	VIN (4.5-5.5V) Note reduced voltage range!
VBAT	VBAT
RESET	RESET
SPI1-MOSI	SSP0_MOSI
SPI1-MISO	SSP0_MISO
SPI1-SCK	SSP0_SCK
GPIO	U4_OE / U4_CLK
UART1-TX/I2C1-SDA	CAN_RD_1 / U3_TXD / I2C1_SDA / U0_TXD
UART1-RX/I2C1-SCL	CAN_TD_1 / U3_RXD / I2C1_SCL / U0_RXD
SPI2-MOSI	I2S_TX_SDA / SSP1_MOSI / T2_MAT_3 / RTC_EV2 / CMP1_IN2
SPI2-MISO	I2S_TX_WS / SSP1_MISO / T2_MAT_2 / RTC_EV1 / CMP1_IN3
SPI2-SCK/UART2-TX	I2S_TX_SCK / SSP1_SCK / T2_MAT_1 / RTC_EV0 / CMP_VREF
UART2-RX	I2S_RX_SDA / SSP1_SSEL / T2_MAT_0 / U1_RTS / CMP_ROSC
AIN0	ADC0_IN[0] / I2S_RX_SCK / T3_CAP_0
AIN1	ADC0_IN[1] / I2S_RX_WS / T3_CAP_1
AIN2	ADC0_IN[2] / I2S_RX_SDA / U3_TXD
AIN3/AOUT	ADC0_IN[3] / DAC_OUT / U3_RXD
AIN4	USB_PWRD2 / USB_VBUS / ADC0_IN[4] / I2C0_SDA / U3_OE (Note: used by USB2 Device interface)
AIN5	USB_OVRCR2n / ADC0_IN[5] / I2C0_SCL
	VSSA
	GND

mbed LPC1768	LPC4088 QuickStart Board
VOUT 3.3V	VOUT 3.3V
VOUT 5V	VOUT 5V Note: not current limited!
NC	U0_TXD / U3_TXD
NC	U0_RXD / U3_RXD
ETH-RDN	RTC ALARM
ETH-RDP	SSP2_MOSI / T2_MAT_2
ETH-TDN	SSP2_MISO / T2_MAT_3
ETH-TDP	U0_OE / T3_MAT_3 / U4_TXD
USB-DM	EXT-USB2-DM
USB-DP	EXT-USB2-DP
CAN-RD	I2S_RX_SCK / CAN_RD_2 / T2_CAP_0 / CMP_ROSC
CAN-TD	I2S_RX_WS / CAN_TD_2 / T2_CAP_1 / CMP_RESET
UART3-TX/I2C2-SDA	SSP2_SCK / T3_MAT_2 / I2C0_SDA
UART3-RX/I2C2-SCL	SSP2_SSEL / U4_RXD / I2C0_SCL
PWMOUT0	SD_CLK / PWM0_1
PWMOUT1	SD_CMD / PWM0_2
PWMOUT2	SD_PWR / PWM0_3 / CMP1_IN1
PWMOUT3	SD_DAT_0 / PWM0_4 / CMP0_IN3
PWMOUT4	SD_DAT_1 / PWM0_5 / CMP1_IN0
PWMOUT5	SD_DAT_2 / PWM0_6
	SD_DAT_3 / PWM0_CAP_0 / CMP1_OUT
	ISP_EN / EINT_0 / NMI



© Embedded Artists AB

TITLE: LPC4088 QuickStart Board rev A

Document Number:

Date: 2013-09-06 12:07:35

Sheet: 9/9